

Evercode™ Whole Transcriptome

Scalable Single Cell Sequencing,
No Instrument Required

Easy to Get Started
Flexible Workflow
Unmatched Sensitivity



Single Cell RNA-Seq in Any Lab

Simple Workflow

An instrument-free workflow takes isolated cells or nuclei to biological insights

1 Fixation of Cells or Nuclei



2 Barcoding and Library Prep



3 Sequencing



4 Data Analysis



No Instrument
Required

Step away from the limitations of hardware-based offerings for a more elegant solution to single cell RNA sequencing (scRNA-seq) and single nuclei RNA sequencing (snRNA-seq).

Exponentially Scalable

Evercode's combinatorial barcoding enables you to dramatically scale up the cells and samples per experiment.

Unmatched Data Quality

Better detect lowly expressed genes and avoid ambient RNA common in droplet-based single cell sequencing.

No Instrument Required

If you have a centrifuge, thermal cycler, and some pipettes, you're ready to go.

Cell and Nuclei Fixation

Fix and store samples as they come in for up to 6 months and then run together later on your schedule. Ideal for time-courses and cross-site collaborations.

Fixation

Cells/nuclei samples are fixed and permeabilized.

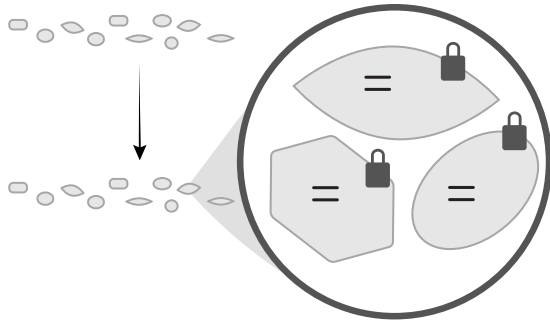

Barcoding Round 1

Split | Fixed cells/nuclei are distributed into wells, and the first sample-specific barcodes are added by in-cell reverse transcription.

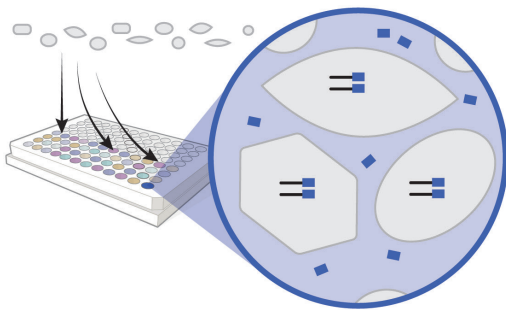

Pool | All the cells are pooled together.

Barcoding Round 2

Split | The pooled cells are distributed across a plate, and an in-cell ligation adds the second barcode.

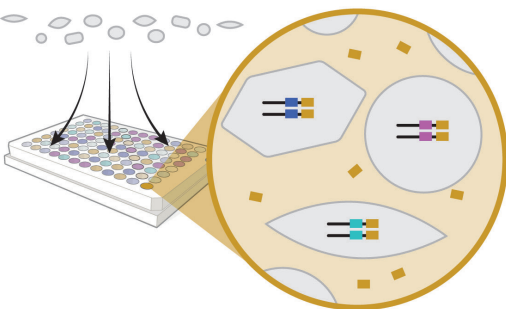

Pool | All the cells are pooled together.

Barcoding Round 3

Split | The pooled cells are again distributed across a plate, and a third barcode is added via in-cell ligation reaction.

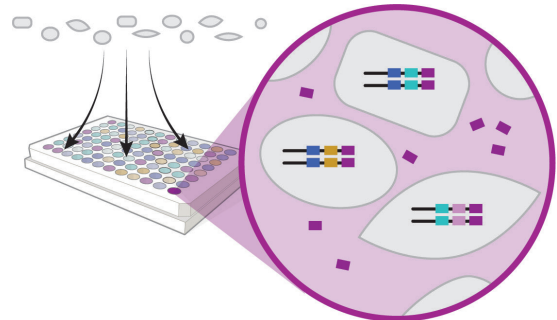

Pool | All the cells are pooled together.

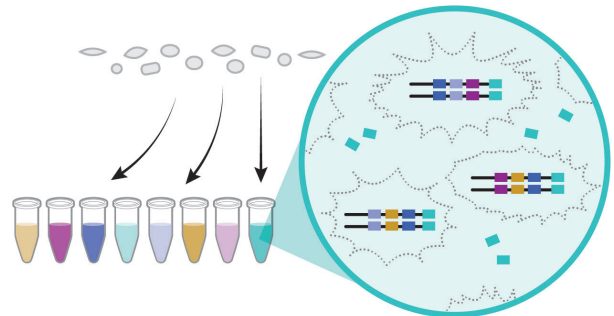

Lysis and Library Prep

Split | The pooled cells are distributed across several sublibraries then lysed. The fourth barcode is added via PCR.



Sequencing and Analysis

Each transcript is assigned to a single cell based on a unique combination of barcodes.

Genes	Barcodes					
	1	2	3	4		
Gene A	—	■	■	■		Cell 1
Gene B	—	■	■	■		
Gene C	—	■	■	■		
Gene A	—	■	■	■		Cell 2
Gene B	—	■	■	■		
Gene D	—	■	■	■		
Gene E	—	■	■	■		Cell 3
Gene F	—	■	■	■		
Gene G	—	■	■	■		

No Instrument Required with Combinatorial Barcoding

The Cell Is
the Reaction
Compartment

Cells are first fixed and permeabilized, turning them into their own reaction vessels, removing the need to capture individual cells in droplets or microwells. The split-pool barcoding process then labels cells with an exponentially large number of barcode combinations making it possible to easily scale beyond other technologies.

Single Cell Data Analysis Made Easy with Trailmaker

Every kit comes with our data analysis platform, Trailmaker™, which transforms sequencing output (FASTQ) into understandable results and publication-ready figures. Trailmaker enables users to process, integrate, explore, plot, and share Evercode Whole Transcriptome data anytime and anywhere with push-button analytics.



Seamlessly Scale Your Single Cell Projects

From Pilot to Millions of Cells & Hundreds of Samples

Regardless of scale, Evercode technology has a kit to fit every study. Whether you want to generate proof of concept results or perform cell atlasing studies, our technology labels cells with thousands to millions of barcode combinations making it possible to easily scale beyond other technologies.

A KIT TO FIT EVERY STUDY

UP TO
12
SAMPLES

10K
CELLS

Evercode WT Mini

Generate proof of concept results for larger studies, grants or just to try the technology.

UP TO
48
SAMPLES

100K
CELLS

Evercode WT

Comprehensive gene profiling across samples, replicates, or timepoints for most studies

UP TO
96
SAMPLES

1M
CELLS

Evercode WT Mega

Expand your science or capabilities by profiling up to 1 million cells per experiment

Fix Now. Run Later.

Many studies require collection of samples over time, and increasingly require larger sample and cell numbers. Simplify your process by fixing samples immediately upon collection and storing them for up to 6 months until they can be processed all together.



Fixation of Nuclei and Cells

Easily work with collaborators and service providers

Minimize bias from batch effects

Conduct time-course studies conveniently

Maximize Research Impact Through Efficient Workflow

- Capture the full heterogeneity of complex samples
- Increase statistical power by including more replicates

96

samples
fixed



1

hour

1

million
cells



2

days

Effortlessly Scale to Millions of Cells

1,084,202 PBMCs IN 1 EXPERIMENT

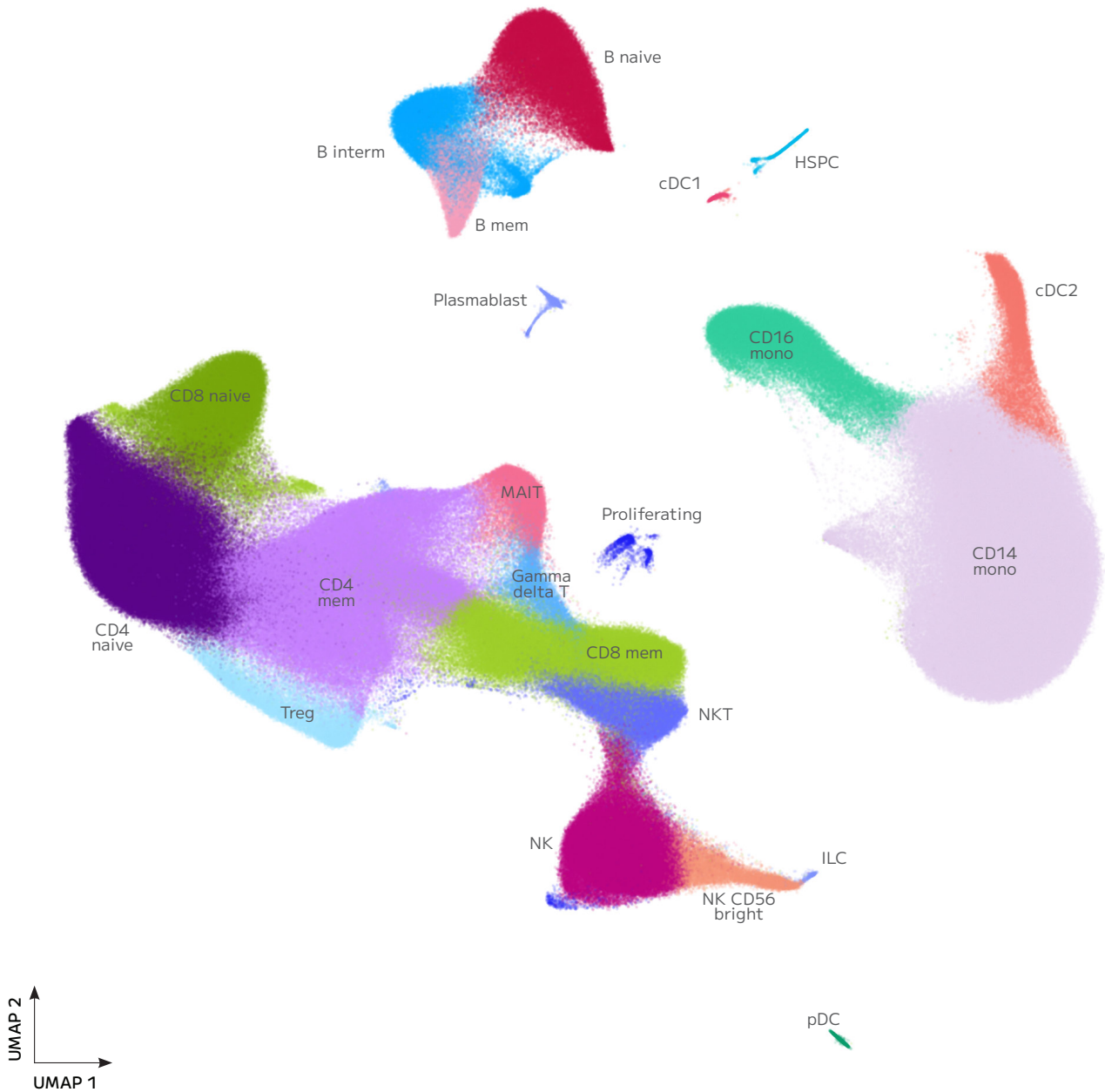

Figure 1. One Million PBMCs. PBMCs isolated from 12 donors were fixed across 48 wells with the Evercode Cell Fixation v3 high throughput plate-based workflow. Fixed samples were processed with a single Evercode WT Mega v3 kit to generate 1,084,202 barcoded cells. Libraries were sequenced a 25B flow cell with an Illumina Novaseq X. Sequencing data were processed with the Parse Biosciences pipeline, integrated, co-clustered, annotated, and visualized as a UMAP.



The Most Scalable Technology

More Cells, More Samples, One Kit

Parse Biosciences Evercode combinatorial barcoding technology scales exponentially without increasing effort or risking batch effects. Droplet-based assays are limited by scaling linearly.

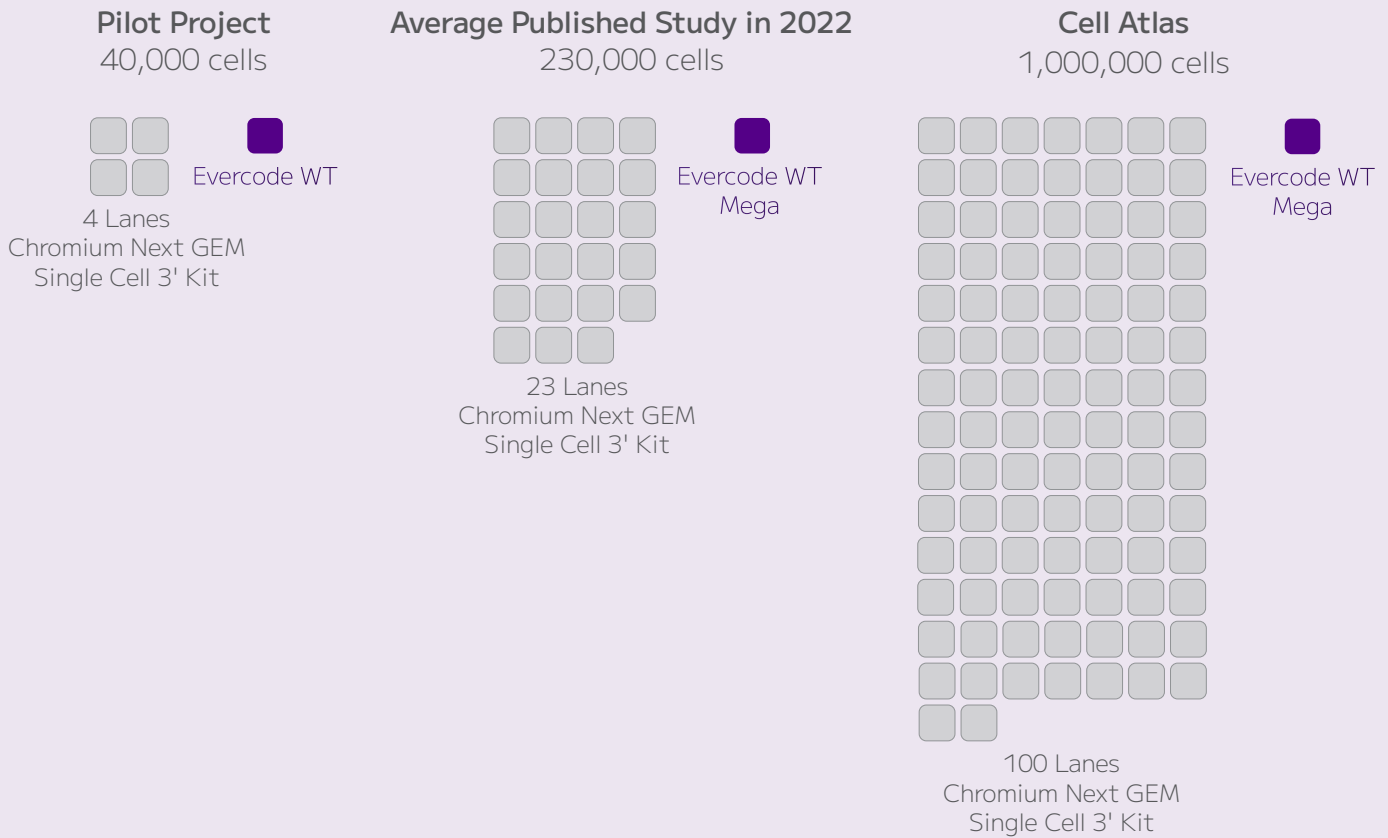

Higher Gene Detection

Evercode Whole Transcriptome technology shows higher gene detection compared to the droplet-based 10x Genomics™ Chromium™ Next GEM Single Cell 3' Kit v3.1 across sample types.

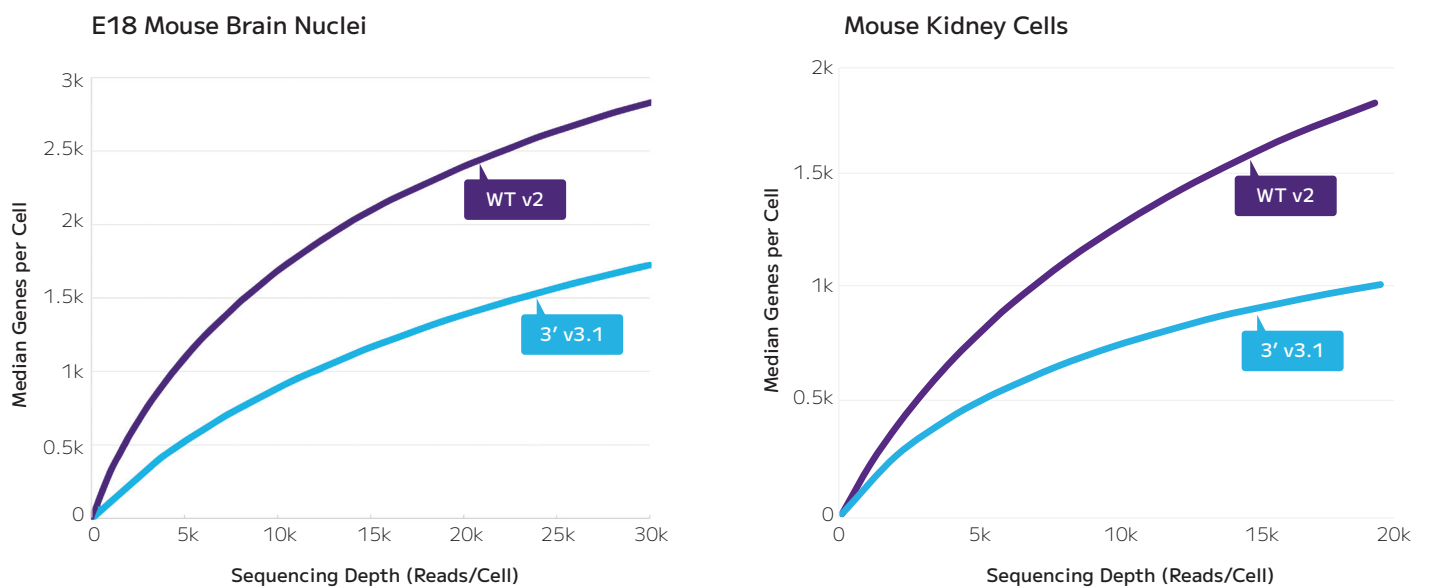

Figure 2. Gene Detection Sensitivity. E18 mouse brain and adult mouse midney samples were split and processed with 10x Genomics™ Chromium™ Next GEM Single Cell 3' Kit v3.1 by a third party service provider and with Evercode WT v2 by Parse Bioscience. Libraries were sequenced by a service provider and analyzed by their respective data analysis pipelines. Median genes detected per cell/nuclei across different sequencing depths is shown for both sample types.

Transition Seamlessly to Evercode

Integrates with Existing Data

Integration of the data from Evercode WT v2 and Next GEM 3' v3.1 resulted in highly concordant clustering and cell proportions, indicating both technologies result in unbiased capture of cell types.

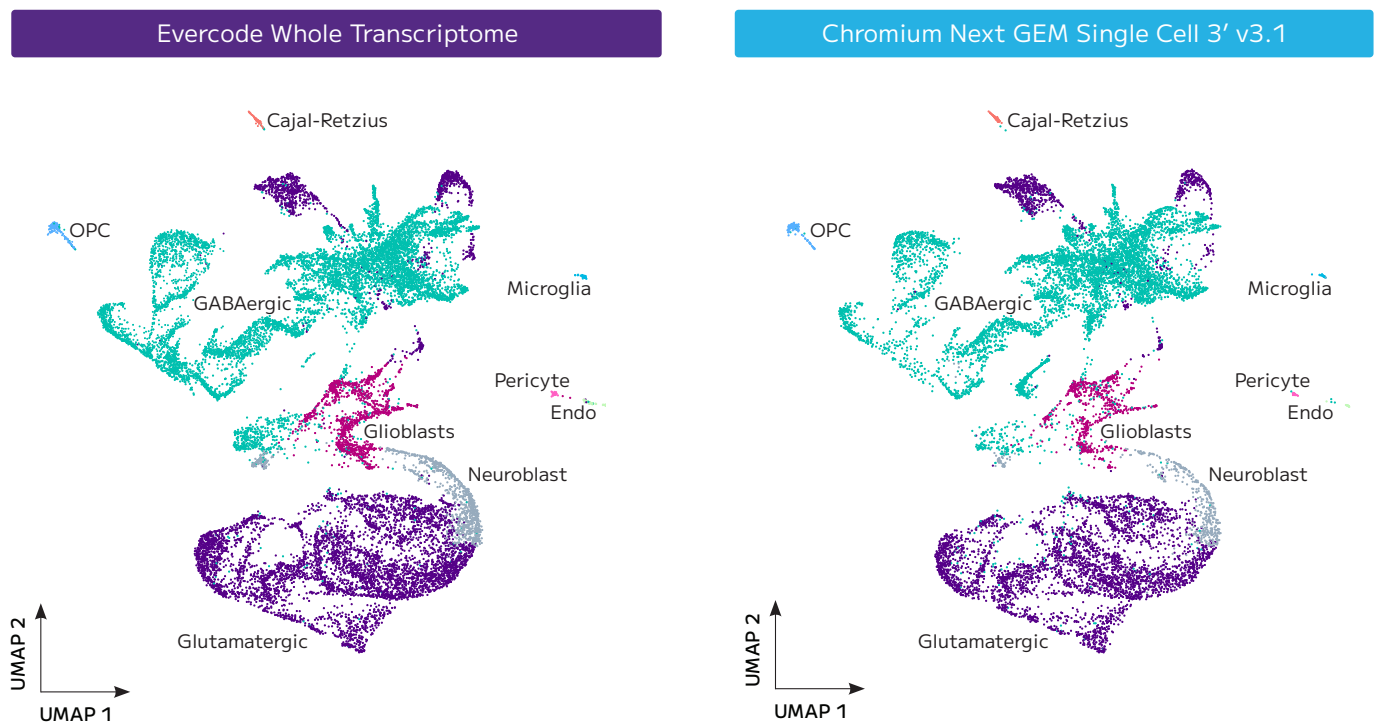
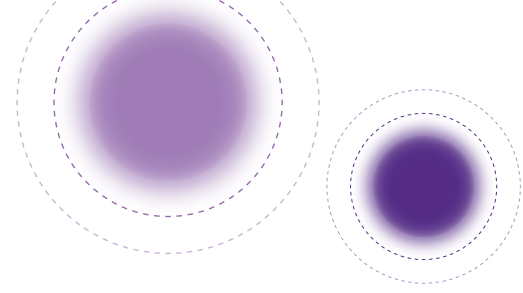

Figure 3. Integrated Evercode WT v2 and Chromium Next GEM 3' v3.1 Clustering. E18 mouse brain samples were split and processed with 10x Genomics Chromium Next GEM Single Cell 3' Kit v3.1 by a third party service provider and with Evercode WT v2 by Parse Biosciences. After downsampling to the same sequencing depth, data from 17,339 nuclei from Evercode WT v2 and 12,967 nuclei from Chromium Next GEM Single Cell 3' Kit v3.1 were integrated, clustered, and visualized with annotations.



Higher Resolution, More Biology

Evercode WT consistently detected more differentially expressed genes (DEG) than Chromium Next GEM 3' v3.1. Most DEG detected in Chromium Next GEM 3' v3.1 data were also detected with Evercode WT.

A. Differentially expressed genes that define cell types

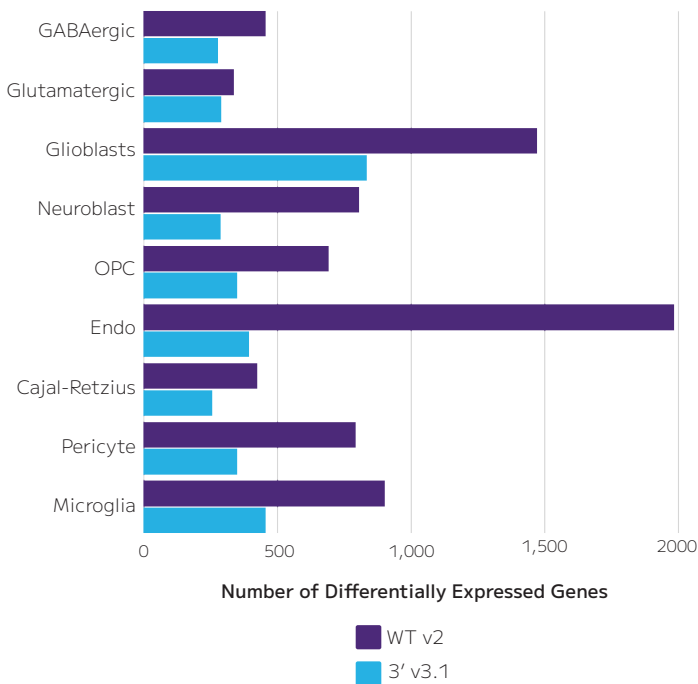

B. GABAergic Neurons

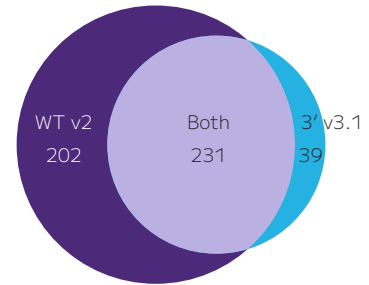

C. Microglia

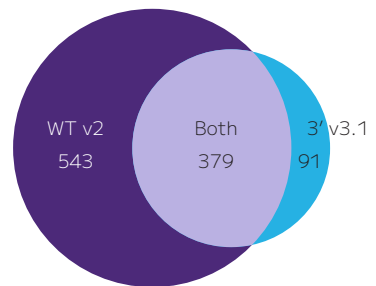

Figure 4. Cell Type Defining Differential Gene Expression. (A) The number of differentially expressed genes for each major cell type, ordered by abundance of the cell type. The uniqueness of differentially expressed genes in the highest (B, GABAergic Neurons) and lowest (C, Microglia) abundant cell types were further investigated. Differentially expressed genes unique to Evercode WT v2 in purple, unique to Chromium Next GEM Single Cell 3' Kit v3.1 in blue, and common to both technologies are shown at the intersection.

Analyze Cleaner Data

Wash Away Ambient RNA

The cell is the reaction compartment with Evercode technology, which means there's no droplets to encapsulate ambient RNA. Prior to library prep, any free floating RNA is washed away leaving behind just the RNA molecules within cells. The pervasive detection of hemoglobin transcripts in the Next GEM 3' v3.1 data suggests that lysed RBCs are a major source of ambient RNA contamination, which is not observed at all with Evercode.

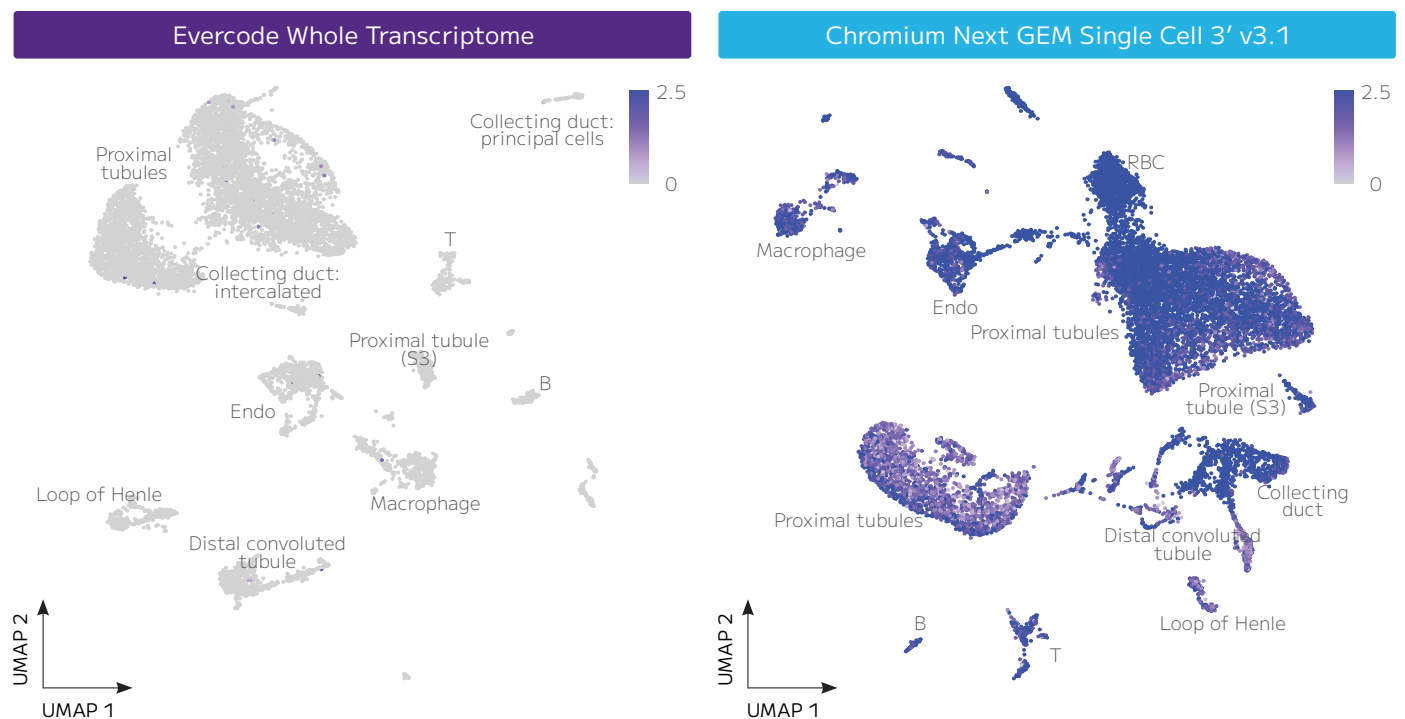

Figure 5. Clustering and Hemoglobin Expression Comparison. Mouse kidney tissue was dissociated into a single cell solution with a Singulator 100 (S2 Genomics). The samples were strained and red blood cells (RBCs) were lysed. The sample was split and half of the sample was prepared with the 10x Genomics Next GEM Single Cell 3' Kit v3.1. The remaining half was fixed with Evercode Cell Fixation v2 and shipped for further processing with Evercode WT v2. Sequencing data were analyzed with each manufacturer's respective analysis pipeline. 9,256 mouse kidney cells from each technology were independently clustered with Seurat and visualized as UMAPs. Expression of hemoglobin alpha, adult chain 1 (Hba-a1) is shown for both technologies.

1200

Trusted by 1,500+ Labs and Growing

800

Advancing Research Globally

The breakneck rate of adoption by single cell researchers is a testament to the utility of Evercode Whole Transcriptome data.

400

For your next experiment, ask us how we can help you get more out of your experiments - smashing through barriers and re-defining what's possible.

2021

2022

2023

PRODUCT**PART NUMBER****Evercode WT Mini v3**

Up to 10,000 cells or nuclei and up to 12 samples

ECWT3100

Evercode WT v3

Up to 100,000 cells or nuclei and up to 48 samples

ECWT3300

Evercode WT Mega v3

Up to 1,000,000 cells or nuclei and up to 96 samples

ECWT3500

Evercode Cell Fixation v3

Up to 12 samples

ECFC3300

Evercode Cell Fixation v3, HT

High throughput fixation for 96 samples

ECFC3501

Evercode Nuclei Fixation v3

Up to 12 samples

ECFN3300

Evercode Nuclei Fixation v3, HT

High throughput fixation for 96 samples

ECFN3501

Your Insights Matter to Us

parsebiosciences.com | info@parsebiosciences.com



For research use only. Not for use in diagnostic procedures.
© 2024 Parse Biosciences, Inc. All rights reserved.
All trademarks are the property of Parse Biosciences unless otherwise specified.

[Explore more resources](#)